

1310 nm Single-mode Transceiver Gigabit Interface Converters (GBIC), 3.3V/5V 1.0625Gbd Fiber Channel/1.25 Gigabit Ethernet



Features

- Compliant with Gigabit Interface Converter Specification
- Compliant with IEEE802.3z Gigabit Ethernet standard
- Compliant with Fiber Channel standard
- SCA-2 Host connector
- Duplex SC connector
- Differential PECL inputs and outputs
- Single power supply 3.3V and 5V
- TTL signal detect indicator
- Hot Pluggable
- Class 1 laser product complies with EN 60825-1

Ordering Information

PART NUMBER	INPUT/OUTPUT	SIGNAL DETECT	VOLTAGE	TEMPERATURE
KS35-CAS-TC-N	AC/AC	TTL	3.3V/5V	0°C to 70 °C

Absolute Maximum Ratings

PARAMETER	SYMBOL	MIN	MAX	UNITS	NOTE
Storage Temperature	T_S	-40	85	°C	
Supply Voltage	V_{CC}	-0.5	6.0	V	
Input Voltage	V_{IN}	-0.5	V_{CC}	V	
Output Current	I_o	---	50	mA	
Operating Current	I_{OP}	---	400	mA	

**1310 nm Single-mode Transceiver
Gigabit Interface Converters (GBIC), 3.3V/5V
1.0625Gbd Fiber Channel/1.25 Gigabit Ethernet**

Recommended Operating Conditions

PARAMETER	SYMBOL	MIN	MAX	UNITS	NOTE
Case Operating Temperature	T_C	0	70	°C	
Supply Voltage	V_{CC}	3.1	5.25	V	
Supply Current	$I_{TX} + I_{RX}$	---	300	mA	

Transmitter Electro-optical Characteristics

$V_{CC} = 3.1\text{ V to }5.25\text{ V}, T_C = 0\text{ °C to }70\text{ °C}$

PARAMETER	SYMBOL	MIN	TYP.	MAX	UNITS	NOTE
Output Optical Power 9/125 μm fiber	P_{out}	-9.5	-5	-3	dBm	Average
Extinction Ratio	ER	9	---	---	dB	
Center Wavelength	λ_C	1270	1310	1355	nm	
Spectral Width (RMS)	$\Delta\lambda$	---	---	2.5	nm	
Rise/Fall Time, (20–80%)	$T_{r,f}$	---	---	260	ps	
Relative Intensity Noise	RIN	---	---	-120	dB/Hz	
Total Jitter	TJ	---	---	227	ps	
Output Eye	Compliant with IEEE802.3z					
Max. P_{out} TX-DISABLE Asserted	P_{OFF}	---	---	-35	dBm	
Differential Input Voltage	V_{DIFF}	0.65	---	2.0	V	
TX Disable Voltage-High	V_{IH}	2.0	---	VCC	V	
TX Disable Voltage-Low	V_{IL}	0	---	0.8	V	

1310 nm Single-mode Transceiver Gigabit Interface Converters (GBIC), 3.3V/5V 1.0625Gbd Fiber Channel/1.25 Gigabit Ethernet

Receiver Electro-optical Characteristics

$V_{CC} = 3.1 \text{ V to } 5.25 \text{ V}, T_C = 0^\circ \text{C to } 70^\circ \text{C}$

PARAMETER	SYMBOL	MIN	TYP.	MAX	UNITS	NOTE
Optical Input Power-maximum	P_{IN}	-3	---	---	dBm	BER < 10^{-12}
Optical Input Power-minimum (Sensitivity)	P_{IN}	---	-25	-20	dBm	BER < 10^{-12}
Operating Center Wavelength	λ_C	1260	---	1610	nm	
Optical Return Loss	ORL	12	---	---	dB	
Signal Detect-Asserted	P_A	---	---	-20	dBm	
Signal Detect-Deasserted	P_D	-35	---	---	dBm	
Stressed Receiver Sensitivity		---	---	-14.4	dBm	Note 1, 2
Differential Output Voltage	V_{DIFF}	0.37	---	2.0	V	
Data Output Rise, Fall Time (20–80%)	$T_{r,f}$	---	---	0.35	ns	
Receiver Loss of Signal Output Voltage-Low	RX_LOS_L	0	---	0.5	V	
Receiver Loss of Signal Output Voltage-High	RX_LOS_H	2.4	---	V_{CC}	V	
Receiver Loss of Signal Assert Time (off to on)	t_{A,RX_LOS}	---	---	100	μs	
Receiver Loss of Signal Assert Time (on to off)	t_{D,RX_LOS}	---	---	100	μs	

Note 1: Measured with conformance test signal at TP3 for BER = 10^{-12} at the eye center.

Note 2: Measured with a transmit signal having a 9 dB extinction ratio. If another extinction ratio is used, the Stressed receiver sensitivity should be corrected for the extinction ratio penalty.

1310 nm Single-mode Transceiver Gigabit Interface Converters (GBIC), 3.3V/5V 1.0625Gbd Fiber Channel/1.25 Gigabit Ethernet

Block Diagram of Transceiver

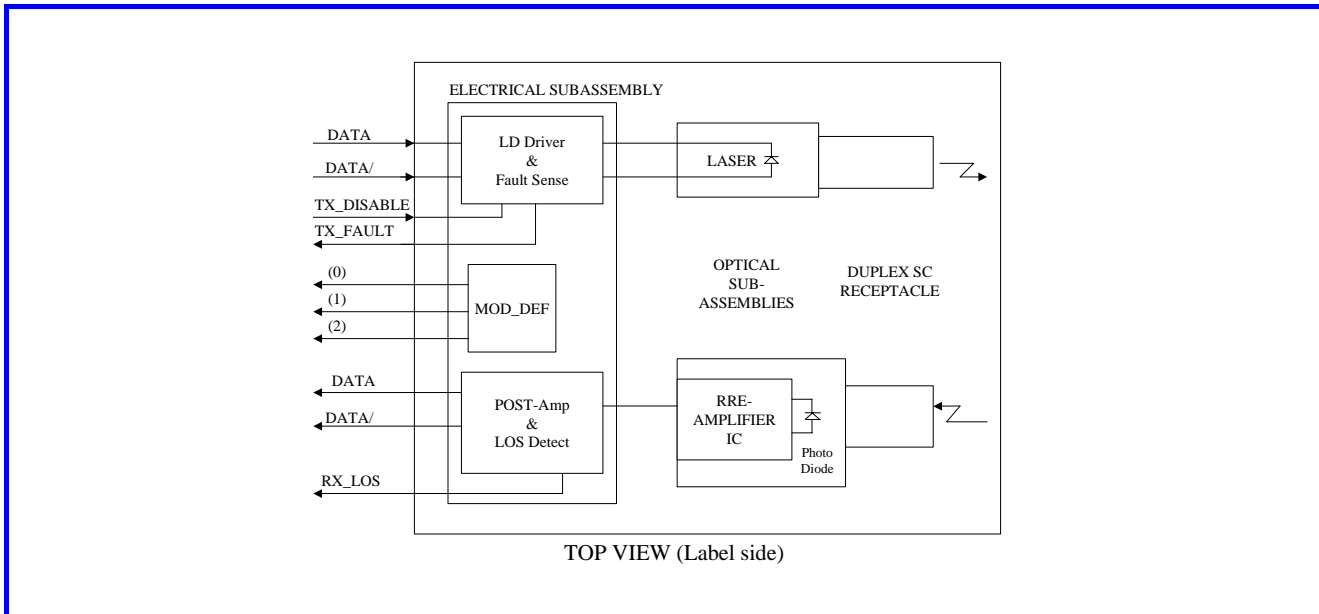

Transmitter Section

The transmitter section consists of a 1310 nm InGaAsP laser in an eye safe optical subassembly (OSA) which mates to the fiber cable. The laser OSA is driven by a LD driver IC which converts differential input LVPECL (3.3V) or PECL (5V) logic signals into an analog laser driving current.

TX_DISABLE

The TX_DISABLE signal is high (TTL logic "1") to turn off the laser output. The laser will turn on when TX_DISABLE is low (TTL logic "0").

Receiver Section

The receiver utilizes an InGaAs PIN photodiode mounted together with a trans-impedance preamplifier IC in an OSA. This OSA is connected to a circuit providing post-amplification quantization, and optical signal detection.

Receive Loss (RX_LOS)

The RX_LOS is high (logic "1") when there is no incoming light from the companion transceiver. This signal is normally used by the system for the diagnostic purpose. The signal is operated in TTL level.

**1310 nm Single-mode Transceiver
Gigabit Interface Converters (GBIC), 3.3V/5V
1.0625Gbd Fiber Channel/1.25 Gigabit Ethernet**

Dimensions

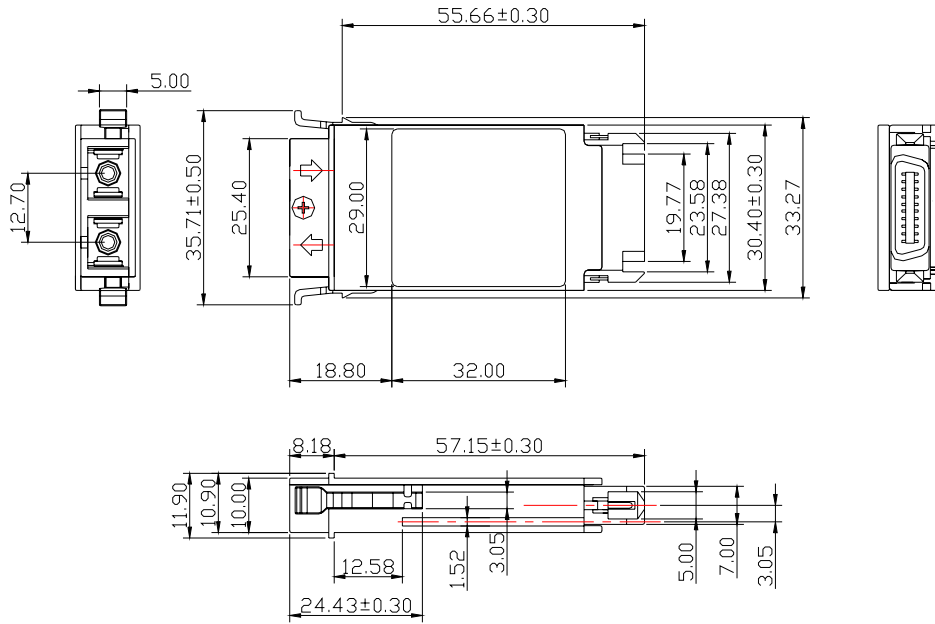

ALL DIMENSIONS ARE ± 0.20 mm UNLESS OTHERWISE SPECIFIED

Unit: mm

1310 nm Single-mode Transceiver Gigabit Interface Converters (GBIC), 3.3V/5V 1.0625Gbd Fiber Channel/1.25 Gigabit Ethernet

Pin Assignment

Pin-Out

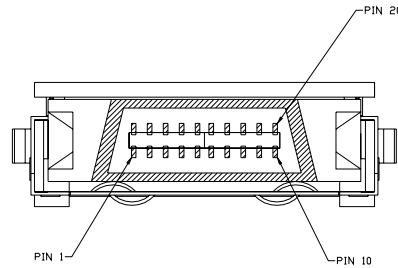

Pin	Signal Name	Description
1	<i>RX_LOS</i>	Receiver Loss of Signal, TTL High, open collector
2	<i>R_GND</i>	Receiver Ground
3	<i>R_GND</i>	Receiver Ground
4	<i>MOD_DEF (0)</i>	TTL Low
5	<i>MOD_DEF (1)</i>	SCL Serial Clock Signal
6	<i>MOD_DEF (2)</i>	SDA Serial Data Signal
7	<i>TX_DISABLE</i>	Transmit Disable
8	<i>T_GND</i>	Transmit Ground
9	<i>T_GND</i>	Transmit Ground
10	<i>TX_FAULT</i>	Transmit Fault
11	<i>R_GND</i>	Receiver Ground
12	<i>RX-</i>	Receive Data Bar, Differential PECL, ac coupled
13	<i>RX+</i>	Receive Data, Differential PECL, ac coupled
14	<i>R_GND</i>	Receiver Ground
15	<i>V_CCR</i>	Receiver Power Supply
16	<i>V_CCT</i>	Transmitter Power Supply
17	<i>T_GND</i>	Transmitter Ground
18	<i>TX+</i>	Transmit Data, Differential PCEL, ac coupled
19	<i>TX-</i>	Transmit Data Bar, Differential PCEL, ac coupled
20	<i>T_GND</i>	Transmitter Ground

**1310 nm Single-mode Transceiver
Gigabit Interface Converters (GBIC), 3.3V/5V
1.0625Gbd Fiber Channel/1.25 Gigabit Ethernet**

Eye Safety Mark

The KS3 series Single-mode transceiver is a class 1 laser product. It complies with EN 60825-1 and FDA 21 CFR 1040.10 and 1040.11. In order to meet laser safety requirements the transceiver shall be operated within the Absolute Maximum Ratings.

Caution

All adjustments have been done at the factory before the shipment of the devices. No maintenance and user serviceable part is required. Tampering with and modifying the performance of the device will result in voided product warranty.

Required Mark

Class 1 Laser Product
Complies with
21 CFR 1040.10 and 1040.11

Note : All information contained in this document is subject to change without notice.