

# 1310 nm Single-mode Transceiver, 19dB margin Gigabit Interface Converters (GBIC), 3.3V/5V 1.0625Gbd Fiber Channel/1.25 Gigabit Ethernet



## Features

- Compliant with Gigabit Interface Converter Specification
- SCA-2 Host connector
- Duplex SC connector
- Differential PECL inputs and outputs
- Single power supply 3.3V and 5V
- TTL signal detect indicator
- Hot Pluggable
- Class 1 laser product complies with EN 60825-1

## Ordering Information

PART NUMBER	INPUT/OUTPUT	SIGNAL DETECT	VOLTAGE	TEMPERATURE
KS35-CAL-TC-N	AC/AC	TTL	3.3V/5V	0°C to 70 °C

## Absolute Maximum Ratings

PARAMETER	SYMBOL	MIN	MAX	UNITS	NOTE
Storage Temperature	$T_S$	-40	85	°C	
Supply Voltage	$V_{CC}$	-0.5	6.0	V	
Input Voltage	$V_{IN}$	-0.5	$V_{CC}$	V	
Output Current	$I_o$	---	50	mA	
Operating Current	$I_{OP}$	---	400	mA	

**1310 nm Single-mode Transceiver, 19dB margin  
Gigabit Interface Converters (GBIC), 3.3V/5V  
1.0625Gbd Fiber Channel/1.25 Gigabit Ethernet**

**Recommended Operating Conditions**

PARAMETER	SYMBOL	MIN	MAX	UNITS	NOTE
Case Operating Temperature	$T_C$	0	70	°C	
Supply Voltage	$V_{CC}$	3.1	5.25	V	
Supply Current(3.3V)	$I_{TX} + I_{RX}$	---	300	mA	
Supply Current(5V)	$I_{TX} + I_{RX}$	---	400	mA	

**Transmitter Electro-optical Characteristics**

$V_{CC} = 3.1\text{ V to }5.25\text{V}, T_C = 0\text{ °C to }70\text{ °C}$

PARAMETER	SYMBOL	MIN	TYP.	MAX	UNITS	NOTE
Output Optical Power <sup>9/125 μm fiber</sup>	$P_{out}$	-4	-1	+3	dBm	Average
Extinction Ratio	$ER$	7	---	---	dB	
Center Wavelength	$\lambda_C$	1280	1310	1355	nm	
Spectral Width (-20dB)	$\Delta\lambda$	---	---	1	nm	
Side Mode Suppression Ratio	$SNSR$	30	---	---	dB	
Rise/Fall Time, (20–80%)	$T_{r,f}$	---	---	260	ps	
Relative Intensity Noise	$RIN$	---	---	-120	dB/Hz	
Total Jitter	$TJ$	---	---	227	ps	
Output Eye	Compliant with IEEE802.3z					
Max. $P_{out}$ TX-DISABLE Asserted	$P_{OFF}$	---	---	-35	dBm	
Differential Input Voltage	$V_{DIFF}$	0.65	---	2.0	V	
TX Disable Voltage-High	$V_{IH}$	2.0	---	VCC	V	
TX Disable Voltage-Low	$V_{IL}$	0	---	0.8	V	

**1310 nm Single-mode Transceiver, 19dB margin  
Gigabit Interface Converters (GBIC), 3.3V/5V  
1.0625Gbd Fiber Channel/1.25 Gigabit Ethernet**

**Receiver Electro-optical Characteristics**

$V_{CC} = 3.1 \text{ V to } 5.25 \text{ V}, T_C = 0^\circ \text{C to } 70^\circ \text{C}$

PARAMETER	SYMBOL	MIN	TYP.	MAX	UNITS	NOTE
Optical Input Power-maximum	$P_{IN}$	-3	---	---	dBm	BER < $10^{-12}$
Optical Input Power-minimum (Sensitivity)	$P_{IN}$	---	-26	-23	dBm	BER < $10^{-12}$
Operating Center Wavelength	$\lambda_C$	1260	---	1610	nm	
Optical Return Loss	$ORL$	12	---	---	dB	
Signal Detect-Asserted	$P_A$	---	---	-23	dBm	
Signal Detect-Deasserted	$P_D$	-35	---	---	dBm	
Differential Output Voltage	$V_{DIFF}$	0.37	---	2.0	V	
Data Output Rise, Fall Time (20–80%)	$T_{r,f}$	---	---	0.35	ns	
Receiver Loss of Signal Output Voltage-Low	$RX\_LOS_L$	0	---	0.5	V	
Receiver Loss of Signal Output Voltage-High	$RX\_LOS_H$	2.4	---	$V_{CC}$	V	
Receiver Loss of Signal Assert Time (off to on)	$t_{A,RX\_LOS}$	---	---	100	$\mu\text{s}$	
Receiver Loss of Signal Assert Time (on to off)	$t_{D,RX\_LOS}$	---	---	100	$\mu\text{s}$	

# 1310 nm Single-mode Transceiver, 19dB margin Gigabit Interface Converters (GBIC), 3.3V/5V 1.0625Gbd Fiber Channel/1.25 Gigabit Ethernet

## Block Diagram of Transceiver

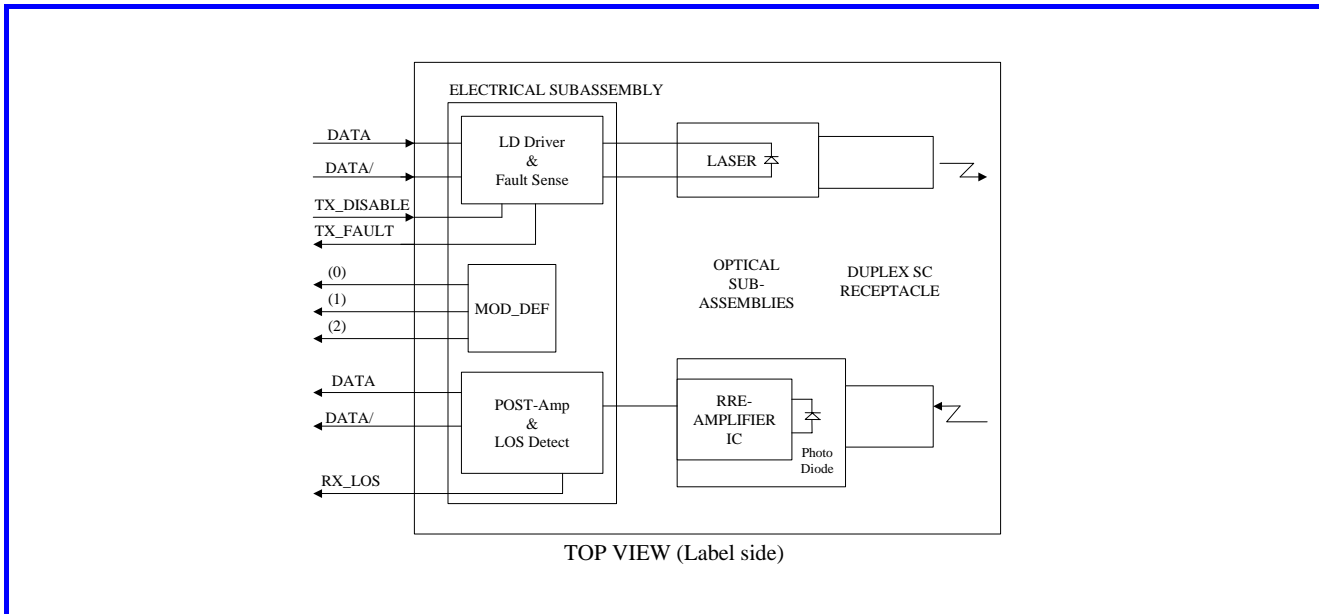

### Transmitter Section

The transmitter section consists of a 1310 nm InGaAsP laser in an eye safe optical subassembly (OSA) which mates to the fiber cable. The laser OSA is driven by a LD driver IC which converts differential input LVPECL (3.3V) or PECL (5V) logic signals into an analog laser driving current.

### TX\_DISABLE

The TX\_DISABLE signal is high (TTL logic "1") to turn off the laser output. The laser will turn on when TX\_DISABLE is low (TTL logic "0").

### Receiver Section

The receiver utilizes an InGaAs PIN photodiode mounted together with a trans-impedance preamplifier IC in an OSA. This OSA is connected to a circuit providing post-amplification quantization, and optical signal detection.

### Receive Loss (RX\_LOS)

The RX\_LOS is high (logic "1") when there is no incoming light from the companion transceiver. This signal is normally used by the system for the diagnostic purpose. The signal is operated in LVTTTL level.

**1310 nm Single-mode Transceiver, 19dB margin  
Gigabit Interface Converters (GBIC), 3.3V/5V  
1.0625Gbd Fiber Channel/1.25 Gigabit Ethernet**

**Dimensions**

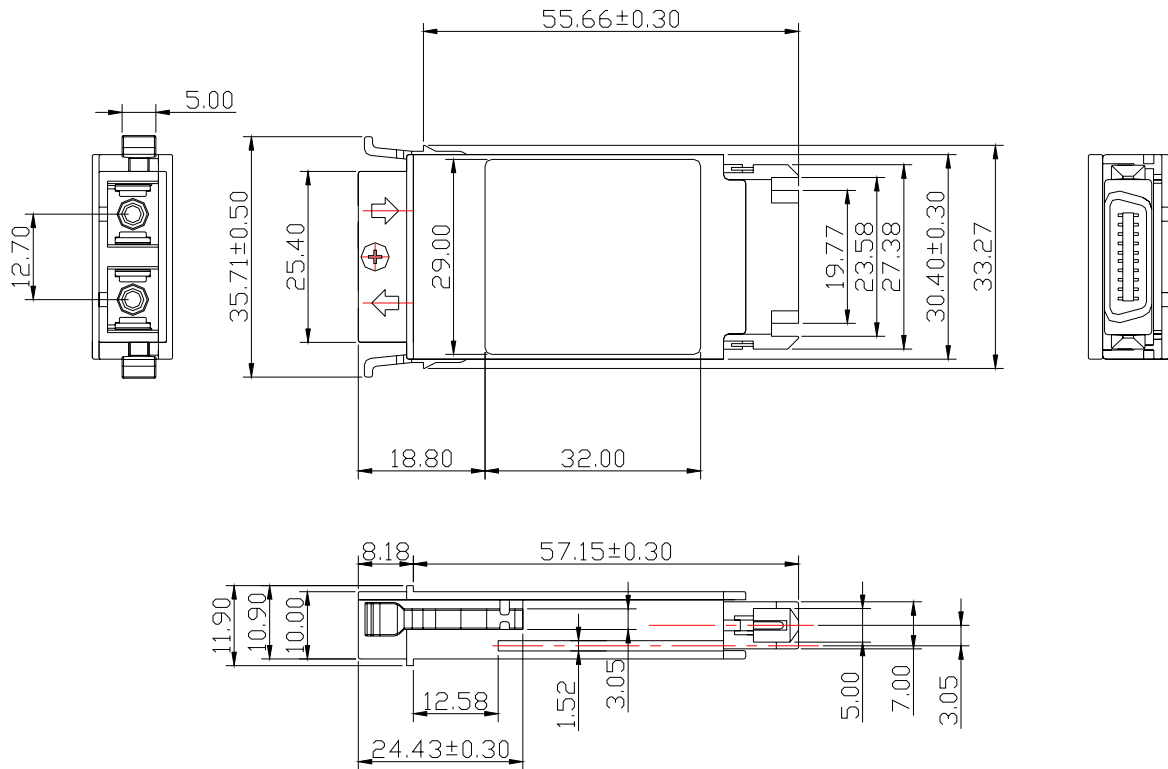

ALL DIMENSIONS ARE  $\pm 0.20$ mm UNLESS OTHERWISE SPECIFIED

Unit: mm

# 1310 nm Single-mode Transceiver, 19dB margin Gigabit Interface Converters (GBIC), 3.3V/5V 1.0625Gbd Fiber Channel/1.25 Gigabit Ethernet

## Pin Assignment

Pin-Out

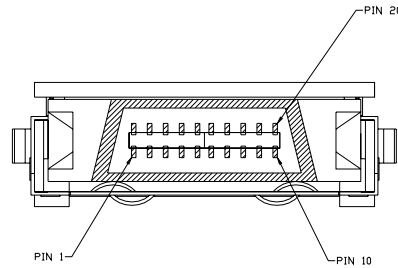

Pin	Signal Name	Description
1	<i>RX_LOS</i>	Receiver Loss of Signal, TTL High, open collector
2	<i>R_GND</i>	Receiver Ground
3	<i>R_GND</i>	Receiver Ground
4	<i>MOD_DEF (0)</i>	TTL Low
5	<i>MOD_DEF (1)</i>	SCL Serial Clock Signal
6	<i>MOD_DEF (2)</i>	SDA Serial Data Signal
7	<i>TX_DISABLE</i>	Transmit Disable
8	<i>T_GND</i>	Transmit Ground
9	<i>T_GND</i>	Transmit Ground
10	<i>TX_FAULT</i>	Transmit Fault
11	<i>R_GND</i>	Receiver Ground
12	<i>RX-</i>	Receive Data Bar, Differential PECL, ac coupled
13	<i>RX+</i>	Receive Data, Differential PECL, ac coupled
14	<i>R_GND</i>	Receiver Ground
15	<i>V_CCR</i>	Receiver Power Supply
16	<i>V_CCT</i>	Transmitter Power Supply
17	<i>T_GND</i>	Transmitter Ground
18	<i>TX+</i>	Transmit Data, Differential PCEL, ac coupled
19	<i>TX-</i>	Transmit Data Bar, Differential PCEL, ac coupled
20	<i>T_GND</i>	Transmitter Ground

## 1310 nm Single-mode Transceiver, 19dB margin Gigabit Interface Converters (GBIC), 3.3V/5V 1.0625Gbd Fiber Channel/1.25 Gigabit Ethernet

### Optical Receptacle Cleaning Recommendations

All fiber stubs inside the receptacle portions were cleaned before shipment. In the event of contamination of the optical ports, the recommended cleaning process is the use of forced nitrogen. If contamination is thought to have remained, the optical ports can be cleaned using a NTT international Cletop® stick type and HFE7100 cleaning fluid. Before the mating of patchcord, the fiber end should be cleaned up by using Cletop® cleaning cassette.

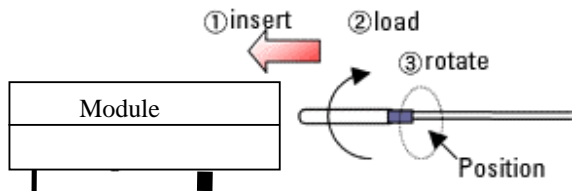
Cleaning of patchcord	Cleaning of fiber stub
	 <ol style="list-style-type: none"><li>1. Insert Ensure that stick is held straight when inserting into sleeve.</li><li>2. Load Apply sufficient pressure (approx 600-700g) to ensure ferrule a little depressed in sleeve.</li><li>3. Rotate Rotate stick clockwise 4-5 times, while ensuring direct contact with ferrule end-face is maintained.</li></ol> <p><i>Notice: Number of possible wipes: Maintenance (repair) ~1 use / piece Equipment construction: 4 uses / piece (max.)</i></p>

Note: The pictures were extracted from NTT-ME website. And the Cletop® is a trademark registered by NTT-ME

**1310 nm Single-mode Transceiver, 19dB margin  
Gigabit Interface Converters (GBIC), 3.3V/5V  
1.0625Gbd Fiber Channel/1.25 Gigabit Ethernet**

---

**Eye Safety Mark**

The KS3 series Single-mode transceiver is a class 1 laser product. It complies with EN 60825-1 and FDA 21 CFR 1040.10 and 1040.11. In order to meet laser safety requirements the transceiver shall be operated within the Absolute Maximum Ratings.

**Caution**

**All adjustments have been done at the factory before the shipment of the devices. No maintenance and user serviceable part is required. Tampering with and modifying the performance of the device will result in voided product warranty.**

**Required Mark**

Class 1 Laser Product  
Complies with  
21 CFR 1040.10 and 1040.11

Note : All information contained in this document is subject to change without notice.