

5V / 622 Mbps InGaAs PIN-TIA Receiver

PT-5100 Series

InGaAs PIN-TIA Receiver

FEATURES

- 2 InGaAs/InP PIN Photodiode with AGC transimpedance amplifier
- 2 Differential ended output
- 2 Single +5V operation
- 2 Speed Up to 622 Mbps
- 2 - 40~+85 °C operation temperature

DESCRIPTION

PT-5100 series is designed as optical signal receivers with AGC transimpedance amplifier. Their wide dynamic ranges, differential outputs are suited for datacom and telecom applications, especially SONET OC-12/ SDH STM-4.

AC / ELECTRICAL AND OPTICAL CHARACTERISTICS (T _C =25°C)						
Symbol	Parameter	Test Conditions	Min.	Typ.	Max.	Unit
	Detection Range		1100	1310	1650	nm
	Active Area			75		μm
G	Differential	λ =1300 nm, 50 MHz	16	20	24	V/mW
BW	Bandwidth	-3 dB point	450	-	-	MHz
Psat	Saturation Power	λ =1300nm	-3	-	-	dBm
Sens	Sensitivity	BER=10 ⁻¹⁰ at 622Mbps	-	-31	-30	dBm
Rout	Output Resistance		-	50	65	ohm
	Speed			622		Mbps

DC / ELECTRICAL CHARACTERISTICS (T _C =25°C)					
Symbol	Parameter	Min.	Typ.	Max.	Unit
V _{CC}	Power Supply	4.7	5.0	5.3	V
I _{CC}	Supply Current (no load)	-	40	60	mA

ABSOLUTE MAXIMUM RATING (T _C =25 °C)			
Symbol	Parameter	Value	Unit
V	Voltage	6	V
T _{opr}	Operating Temperature	-40~+85	°C
T _{stg}	Storage Temperature	-40~+85	°C

MECHANICAL DIMENSION (mm) and PIN ASSIGNMENT

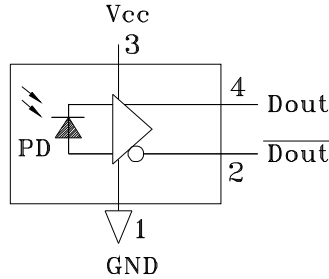
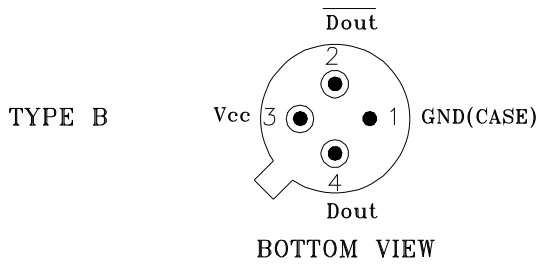
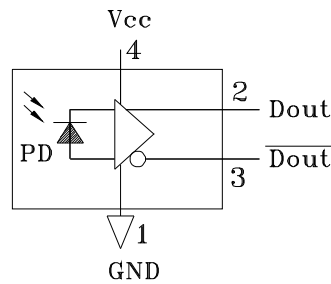
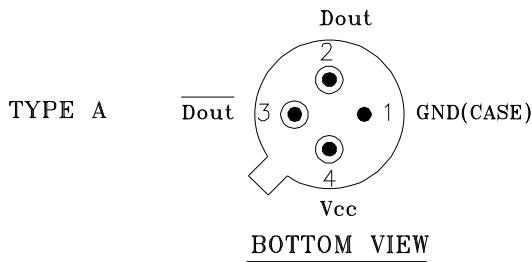
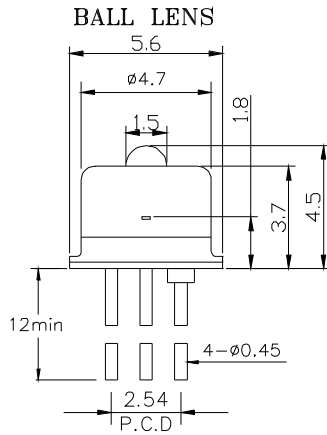

Note: Specifications subject to change without notice.

ORDER INFORMATION

Part No.: P T - 5 1 0

Code	Voltage
0	5V
3	3.3V

Code	PIN Assignment
Blank	Type A
B	Type B
