

**1550 nm Single-mode Transceiver (35dB margin, 120KM)  
1x9, SC Duplex Connector, 5.0 V  
155 Mbps ATM/SONET OC-3/SDH STM-1/Fast Ethernet**



### Features

- Compliant with 155 Mbps ATM and SONET OC-3 SDH STM-1 (L1.2)
- Industry standard 1x9 footprint
- SC duplex connector
- Single power supply 5.0 V
- Differential PECL inputs and outputs
- Compatible with solder and aqueous wash processes
- Class 1 laser product complies with EN 60825-1

### Ordering Information

PART NUMBER	INPUT/OUTPUT	SIGNAL DETECT	VOLTAGE	TEMPERATURE
KS42-A5U-PI-N	DC/DC	PECL	5.0 V	-40°C to 85 °C

### Absolute Maximum Ratings

PARAMETER	SYMBOL	MIN	MAX	UNITS	NOTE
Storage Temperature	$T_S$	-40	85	°C	
Supply Voltage	$V_{CC}$	-0.5	6.0	V	
Input Voltage	$V_{IN}$	-0.5	$V_{CC}$	V	
Output Current	$I_o$	---	50	mA	
Operating Current	$I_{OP}$	---	400	mA	
Soldering Temperature	$T_{SOLD}$	---	260	°C	10 seconds on leads

**1550 nm Single-mode Transceiver (35dB margin, 120KM)  
1x9, SC Duplex Connector, 5.0 V  
155 Mbps ATM/SONET OC-3/SDH STM-1/Fast Ethernet**

### Operating Environment

PARAMETER	SYMBOL	MIN	MAX	UNITS	NOTE
Ambient Operating Temperature	$T_{AMB}$	-40	85	°C	
Supply Voltage	$V_{CC}$	4.75	5.25	V	

### Transmitter Electro-optical Characteristics

( $V_{CC} = 4.75 \text{ V to } 5.25 \text{ V}$ ,  $T_A = -40 \text{ }^\circ\text{C to } 85 \text{ }^\circ\text{C}$ )

PARAMETER	SYMBOL	MIN	TYP.	MAX	UNITS	NOTE
Data Rate	$B$	50	155	200	Mb/s	
Output Optical Power 9/125 $\mu\text{m}$ fiber	$P_{out}$	0	---	+5	dBm	Average
Extinction Ratio	$ER$	10	---	---	dB	
Center Wavelength	$\lambda_c$	1530	1550	1570	nm	
Spectral Width (-20dB)	$\Delta\lambda$	---	---	1	nm	
Side Mode Suppression Ratio	$SNSR$	30	---	---	dB	
Rise/Fall Time (10–90%)	$T_{r,f}$	---	1	2	ns	
Output Eye	Compliant with Telcordia GR-253-CORE Issue 3 and ITU-T recommendation G-957					
Power Supply Current	$I_{CC}$	---	---	140	mA	Note 1
Transmitter Data Input Voltage-High	$V_{IH} - V_{CC}$	-1.1	---	-0.74	V	Note 2
Transmitter Data Input Voltage-Low	$V_{IL} - V_{CC}$	-2.0	---	-1.58	V	Note 2
Transmitter Data Input Differential Voltage	$V_{DIFF}$	0.3	---	1.6	V	Note 2

Note 1: Not including the terminations.

Note 2: These inputs are compatible with 10K, 10KH and 100K ECL and PECL input.

**1550 nm Single-mode Transceiver (35dB margin, 120KM)  
1x9, SC Duplex Connector, 5.0 V  
155 Mbps ATM/SONET OC-3/SDH STM-1/Fast Ethernet**

**Receiver Electro-optical Characteristics**

( $V_{CC} = 4.75 \text{ V to } 5.25 \text{ V}$ ,  $T_A = -40^\circ \text{ C to } 85^\circ \text{ C}$ )

PARAMETER	SYMBOL	MIN	TYP.	MAX	UNITS	NOTE
Data Rate	$B$	50	155	200	Mb/s	
Optical Input Power-maximum	$P_{IN}$	0	---	---	dBm	Note 1
Optical Input Power-minimum (Sensitivity)	$P_{IN}$	---	---	-35	dBm	Note 1
Operating Center Wavelength	$\lambda_C$	1260	---	1620	nm	
Signal Detect-Asserted	$P_A$	---	---	-35	dBm	Average
Signal Detect-Deasserted	$P_D$	-47	---	---	dBm	Average
Signal Detect-Hysteresis	$P_A - P_D$	1.0	---	---	dB	
Signal Detect Output voltage-High	$V_{OH} - V_{CC}$	-1.1	---	-0.74	V	Note 2
Signal Detect Output voltage-Low	$V_{OL} - V_{CC}$	-2.0	---	-1.58	V	Note 2
Power Supply Current	$I_{CC}$	---	---	100	mA	Note 3
Data Output Rise, Fall Time (10-90%)	$T_{r,f}$	---	1	2	ns	
Data Output Voltage-High	$V_{OH} - V_{CC}$	-1.1	---	-0.74	V	Note 2
Data Output Voltage-Low	$V_{OL} - V_{CC}$	-2.0	---	-1.58	V	Note 2

Note 1: The input data is at 155.52 Mbps,  $2^{23}-1$  PRBS data pattern with 72 "1"s and 72 "0"s inserted per the ITU-T recommendation G.958 Appendix 1. The receiver is guaranteed to provide output data with Bit Error Rate (BER) better than or equal to  $1 \times 10^{-10}$ .

Note 2: These outputs are compatible with 10K, 10KH and 100K ECL and PECL input.

Note 3: The current exclude the output load current.

**1550 nm Single-mode Transceiver (35dB margin, 120KM)  
1x9, SC Duplex Connector, 5.0 V  
155 Mbps ATM/SONET OC-3/SDH STM-1/Fast Ethernet**

**Block Diagram of Transceiver**

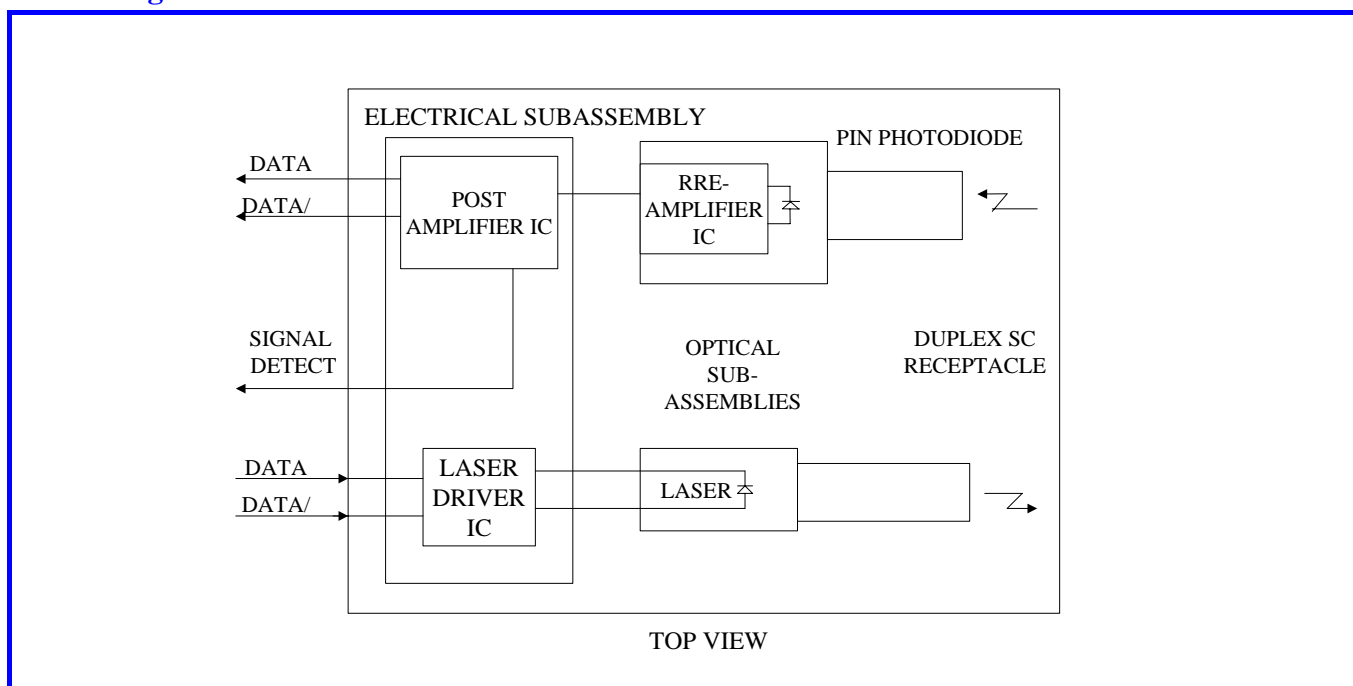

**Transmitter Section**

The transmitter section consists of a 1550 nm InGaAsP laser in an eye safe optical subassembly (OSA) which mates to the fiber cable. The laser OSA is driven by a LD driver IC which converts differential input PECL logic signals into an analog laser driving current.

**Receiver Section**

The receiver utilizes an InGaAs PIN photodiode mounted together with a trans-impedance preamplifier IC in an OSA. This OSA is connected to a circuit providing post-amplification quantization, and optical signal detection.

**Receiver Signal Detect**

Signal Detect is a basic fiber failure indicator. This is a single-ended PECL output. As the input optical power is decreased, Signal Detect will switch from high to low (deassert point) somewhere between sensitivity and the no light input level. As the input optical power is increased from very low levels, Signal Detect will switch back from low to high (assert point). The assert level will be at least 1.0 dB higher than the deassert level.

**1550 nm Single-mode Transceiver (35dB margin, 120KM)  
1x9, SC Duplex Connector, 5.0 V  
155 Mbps ATM/SONET OC-3/SDH STM-1/Fast Ethernet**

**Typical BER Performance of Receiver versus Input Optical Power Level**

**Connection Diagram**

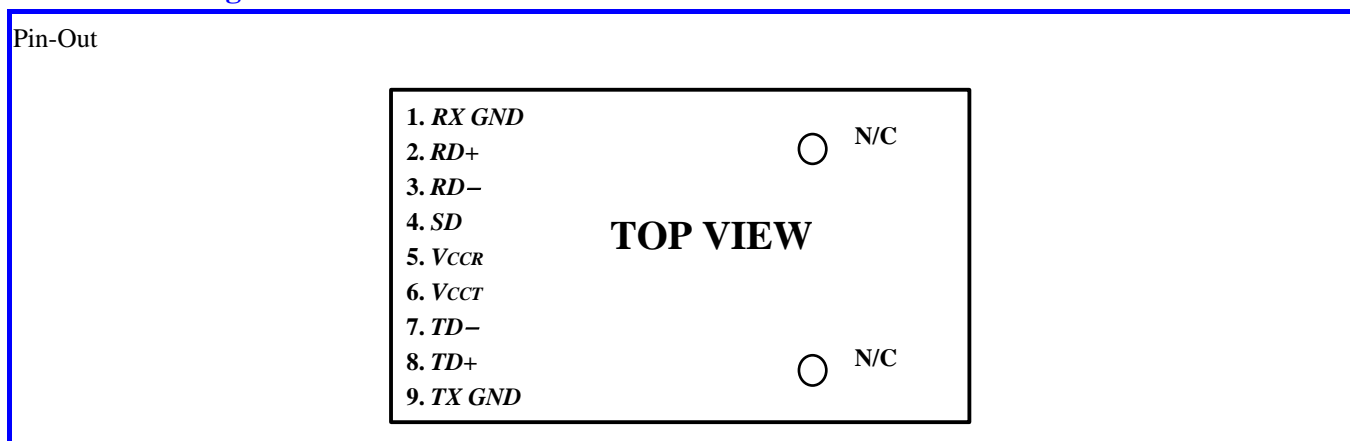

PIN	SYMBOL	DESCRIPTION
1	<i>RX GND</i>	Receiver Signal Ground. Directly connect this pin to the receiver ground plane.
2	<i>RD+</i>	<i>RD+</i> is an open-emitter output circuit. Terminate this high-speed differential PECL output with standard PECL techniques at the follow-on device input pin. (See recommended circuit schematic)
3	<i>RD-</i>	<i>RD-</i> is an open-emitter output circuit . Terminate this high-speed differential PECL output with standard PECL techniques at the follow-on device input pin. (See recommended circuit schematic)
4	<i>SD</i>	Signal Detect. Normal optical input levels to the receiver result in a logic “1” output, $V_{OH}$ , asserted. Low input optical levels to the receiver result in a fault condition indicated by a logic “0” output $V_{OL}$ , deasserted Signal Detect is a single-ended PECL output. <i>SD</i> can be terminated with PECL techniques via $50 \Omega$ to $V_{CCR} - 2$ V. Alternatively, <i>SD</i> can be loaded with a $180 \Omega$ resistor to <i>RX GND</i> to conserve electrical power with small compromise to signal quality. If Signal Detect output is not used, leave it open-circuited. This Signal Detect output can be used to drive a PECL input on an upstream circuit, such as, Signal Detect input or Loss of Signal-bar.
5	$V_{CCR}$	Receiver Power Supply. Provide +5.0 Vdc via the recommended receiver power supply filter circuit. Locate the power supply filter circuit as close as possible to the $V_{CCR}$ pin.
6	$V_{CCT}$	Transmitter Power Supply. Provide +5.0 Vdc via the recommended transmitter power supply filter circuit. Locate the power supply filter circuit as close as possible to the $V_{CCT}$ pin.
7	<i>TD-</i>	Transmitter Data In-Bar. Terminate this high-speed differential PECL input with standard PECL techniques at the transmitter input pin. (See recommended circuit schematic)
8	<i>TD+</i>	Transmitter Data In. Terminate this high-speed differential PECL input with standard PECL techniques at the transmitter input pin. (See recommended circuit schematic)

**1550 nm Single-mode Transceiver (35dB margin, 120KM)**  
**1x9, SC Duplex Connector, 5.0 V**  
**155 Mbps ATM/SONET OC-3/SDH STM-1/Fast Ethernet**

---

- 9    *TX GND*    Transmitter Signal Ground.  
Directly connect this pin to the transmitter signal ground plane. Directly connect this pin to the transmitter ground plane.
-



**1550 nm Single-mode Transceiver (35dB margin, 120KM)  
1x9, SC Duplex Connector, 5.0 V  
155 Mbps ATM/SONET OC-3/SDH STM-1/Fast Ethernet**

**Recommended Board Layout Hole Pattern**

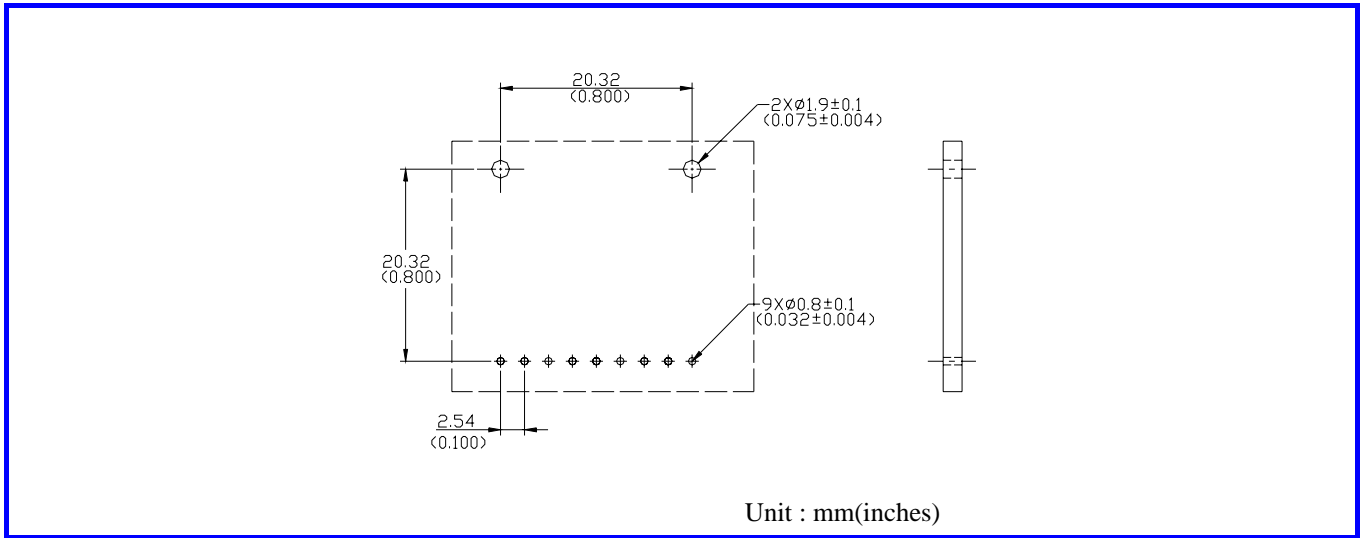

This transceiver is compatible with industry standard wave or hand solder processes. After wash process, all moisture must be completely remove from the module. The transceiver is supplied with a process plug to prevent contamination during wave solder and aqueous rinse as well as during handling, shipping or storage.

Solder fluxes should be water-soluble, organic solder fluxes. Recommended cleaning and degreasing chemicals for these transceivers are alcohol's (methyl, isopropyl, isobutyl), aliphatics (hexane, heptane) and other chemicals, such as soap solution or naphtha. Do not use partially halogenated hydrocarbons for cleaning/degreasing.

**1550 nm Single-mode Transceiver (35dB margin, 120KM)  
1x9, SC Duplex Connector, 5.0 V  
155 Mbps ATM/SONET OC-3/SDH STM-1/Fast Ethernet**

**Drawing Dimensions**

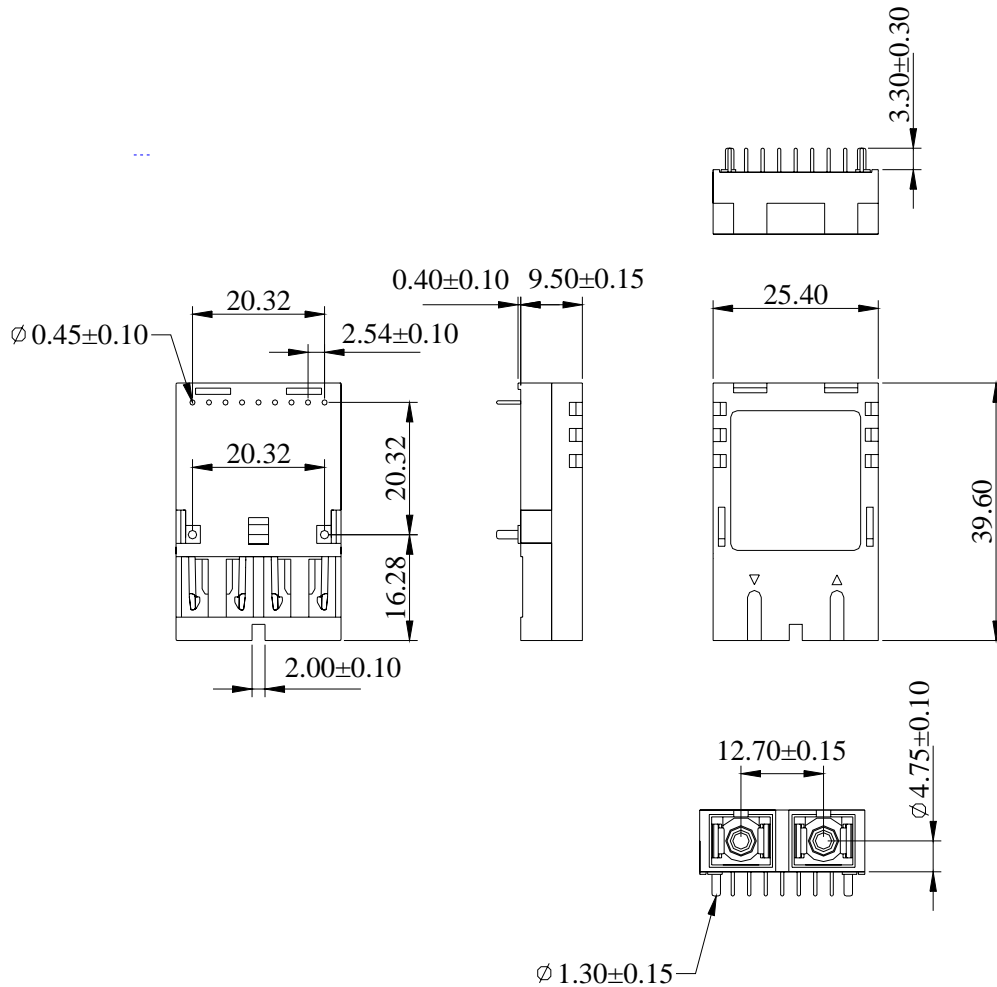

ALL DIMENSIONS ARE  $\pm 0.20$ mm UNLESS OTHERWISE SPECIFIED

Unit : mm

**1550 nm Single-mode Transceiver (35dB margin, 120KM)  
1x9, SC Duplex Connector, 5.0 V  
155 Mbps ATM/SONET OC-3/SDH STM-1/Fast Ethernet**

**Optical Receptacle Cleaning Recommendations**

All fiber stubs inside the receptacle portions were cleaned before shipment. In the event of contamination of the optical ports, the recommended cleaning process is the use of forced nitrogen. If contamination is thought to have remained, the optical ports can be cleaned using a NTT international Cletop® stick type and HFE7100 cleaning fluid. Before the mating of patchcord, the fiber end should be cleaned up by using Cletop® cleaning cassette.

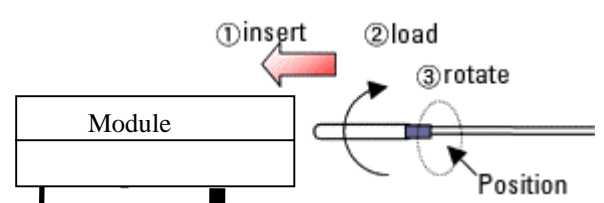
<p><b>Cleaning of patchcord</b></p> 	<p><b>Cleaning of fiber stub</b></p>  <ol style="list-style-type: none"><li>1. Insert Ensure that stick is held straight when inserting into sleeve.</li><li>2. Load Apply sufficient pressure (approx 600-700g) to ensure ferrule a little depressed in sleeve.</li><li>3. Rotate Rotate stick clockwise 4-5 times, while ensuring direct contact with ferrule end-face is maintained.</li></ol> <p><i>Notice: Number of possible wipes: Maintenance (repair) ~1 use / piece Equipment construction: 4 uses / piece (max.)</i></p>
--	---

Note: The pictures were extracted from NTT-ME website. And the Cletop® is a trademark registered by NTT-ME

**1550 nm Single-mode Transceiver (35dB margin, 120KM)  
1x9, SC Duplex Connector, 5.0 V  
155 Mbps ATM/SONET OC-3/SDH STM-1/Fast Ethernet**

---

**Eye Safety Mark**

The KS4 series Single-mode transceiver is a class 1 laser product. It complies with EN 60825-1 and FDA 21 CFR 1040.10 and 1040.11. In order to meet laser safety requirements the transceiver shall be operated within the Absolute Maximum Ratings.

**Caution**

**All adjustments have been done at the factory before the shipment of the devices. No maintenance and user serviceable part is required. Tampering with and modifying the performance of the device will result in voided product warranty.**

**Required Mark**

Class 1 Laser Product  
Complies with  
21 CFR 1040.10 and 1040.11

Note : All information contained in this document is subject to change without notice.